

# Q 85

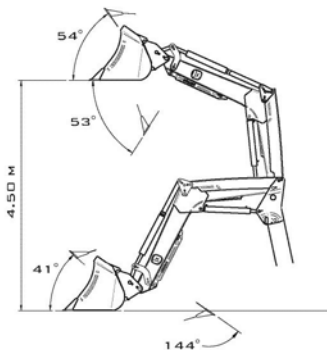

## WORKING ANGLES\*

41° min. crowd angle | 53° min. dump angle

## LIFT HEIGHT

187"/4.75 metres at pivot pin

177"/4.50 metres under level implement\*

## LIFT TIME

8.5 seconds to max. lift height at 15.8 gal/min / 60 l/min

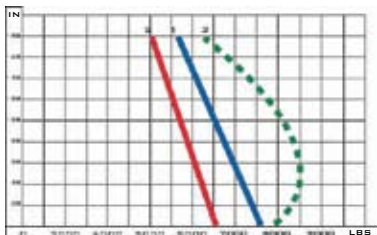

## LIFT CAPACITY AT 2683 PSI / 18.5 MPA

- 1: 7700 lbs/3500 kg at pivot pin, ground level  
5610 lbs/2550 kg at pivot pin, max. lift height
- 2: 6600 lbs/3000 kg 31.5"/80 cm forward of pivot pin, ground level  
6160 lbs/2800 kg 31.5"/80 cm forward of pivot pin, 1.5 m lift height  
4950 lbs/2250 kg 31.5"/80 cm forward of pivot pin, max. lift height
- 3: Break-out force 31.5"/80 cm forward of pivot pin

## TRACTOR SIZE

>150 HP. >112 KW and/or

**Rec. tractor weight:** max. 22.000 lbs/10.000 kg

*In addition to engine strength, the tractor's weight and size influence your choice of loader.*

**LOADER WEIGHT: 1778 LBS/808 KG**